

HONEYWELL

DC 1010 / 1020

1030 / 1040

DIGITAL CONTROLLER
PRODUCT MANUAL

51-52-25-113

06/02

Before using this manual, please check to ensure the Model number, input type Range and output match your requirements.

1. Front Panel Overview

1.1 Display

PV : Process Value, 4-digit display (Color Red)

SP : Set Point, 4-digit display (Color Green)

1.2 LED Indicators

OUT1 : Output 1, color green

OUT2 : Output 2, color green

AT : Auto-Tuning, color yellow

PRO : Program, color yellow

AL1 : Alarm 1, color red

AL2 : Alarm 2, color red

MAN : Manual, color yellow

1.3 Keys

SET : MODE & SET key

 : SHIFT key

 : DOWN key

 : UP key

A/M : Auto/Manual key

2. Auto Tuning

2.1 When AT is set to 'YES', auto tuning can be initiated.

2.2 After completion of auto tuning, the PID parameter are automatically Entered into memory.

2.3 ATVL = auto tuning offset, the off set value when entered will be calculated and subtracted from the SP.

(It prevents over-shooting during auto tuning)

SP-ATVL = Auto-tuning value, ATVL = Auto tuning offset

Ex.) SP = 200°C, ATVL = 5, Auto tuning point is at 195°C

* ATVL means auto-tuning point (195°C) in the above example.

2.4 Auto tuning failure

2.4.1 ATVL is too large.

→ If unsure, set ATVL = 0)

2.4.2 Process lag is to long for Auto Tune to function correctly.

→ Set PID parameter manually.

3. Error Information

1 n 1E	Open circuit sensor input 1
* A d C F	A/D converter failed
* C J C E	Cold junction compensation failed
1 n 2 E	Open circuit of sensor input 2
U U U 1	PV exceeds USPL
n n n 1	PV under LSPL
U U U 2	Input 2 signal has exceeded the upper limit
n n n 2	Input 2 signal has exceeded the lower limit
* r A C F	RAM failed
1 n E F	Interface failed
A U E F	Auto tuning failed

Note) Error * code indicates critical failure unit must be replaced.

4. Operating Flow

4.1 Level 1

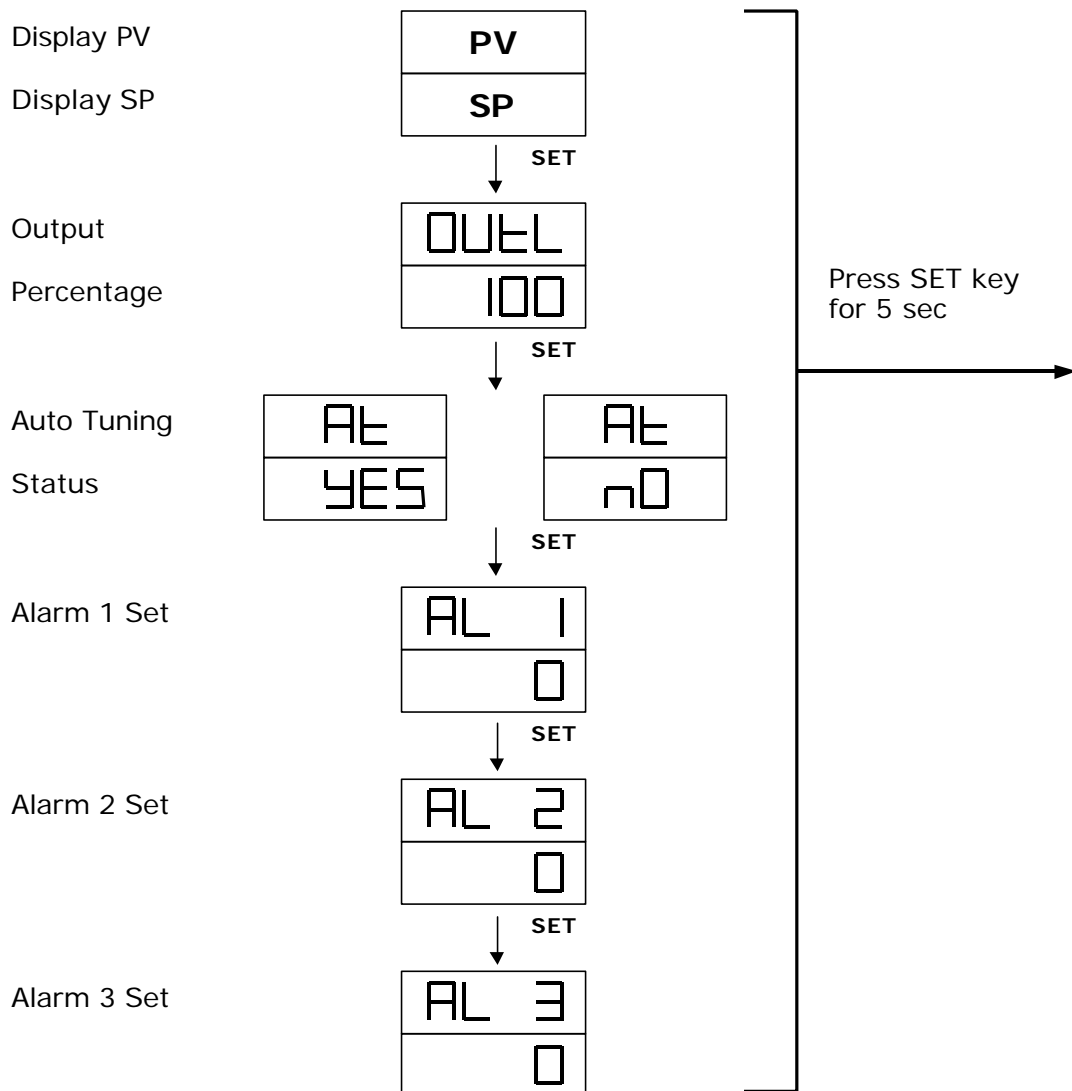

- 4.1.1 Press the SHIFT key (◀) to change the parameters, when the SHIFT key is pressed, the first digit will start to blink. Press UP key (▲) or DOWN key (▼) to increase or decrease the value of the digit, then press SHIFT key again to go to the next digit, repeat the above procedure until the required has been selected. Press the SET key to enter the desired value.
- 4.1.2 The SET key also has the function of changing MODEs. If SET key is pressed, the display shows the next MODE.
- 4.1.3 Press SET key for 5 sec. The display goes to level 2, press the SET key again to return to level 1.
- 4.1.4 If any key is not pressed for 1 minute the display will return to level 1.
- 4.1.5 If the A/M key is pressed the controller will switch to level 1.
- 4.1.6 If the output percentage is "0", the controller output is off.

4.2 Level 2

<div style="border: 1px solid black; padding: 2px; display: inline-block; text-align: center;">P1</div> <div style="border: 1px solid black; padding: 2px; display: inline-block; text-align: center;">3</div> ↓ SET	Main Control Proportional Band	Range: 0~200% ON/OFF at P=0
<div style="border: 1px solid black; padding: 2px; display: inline-block; text-align: center;">I1</div> <div style="border: 1px solid black; padding: 2px; display: inline-block; text-align: center;">240</div> ↓ SET	Main Control Integral Time	Range: 0~3600 sec Integral off at I=0
<div style="border: 1px solid black; padding: 2px; display: inline-block; text-align: center;">d1</div> <div style="border: 1px solid black; padding: 2px; display: inline-block; text-align: center;">60</div> ↓ SET	Main Control Derivative Time	Range: 0~900 sec Derivative off at D=0
<div style="border: 1px solid black; padding: 2px; display: inline-block; text-align: center;">db1</div> <div style="border: 1px solid black; padding: 2px; display: inline-block; text-align: center;">0</div> ↓ SET	Main Control Dead-band Time	Dead Time Compensation Range: 0~1000 sec
<div style="border: 1px solid black; padding: 2px; display: inline-block; text-align: center;">AETL</div> <div style="border: 1px solid black; padding: 2px; display: inline-block; text-align: center;">0</div> ↓ SET	Main Control Auto Tuning off-set	Range: 0~USPL
<div style="border: 1px solid black; padding: 2px; display: inline-block; text-align: center;">CYE1</div> <div style="border: 1px solid black; padding: 2px; display: inline-block; text-align: center;">10</div> ↓ SET	Main Control Proportional Cycle	Output (SSR → 1, 4~20mA→0, relay→over 10) Range: 0~150 sec * Refer to 8.10 Cycle Time
<div style="border: 1px solid black; padding: 2px; display: inline-block; text-align: center;">HYS1</div> <div style="border: 1px solid black; padding: 2px; display: inline-block; text-align: center;">1</div> ↓ SET	Main Control Hysterisis	For ON/OFF control only Range: 0~1000
<div style="border: 1px solid black; padding: 2px; display: inline-block; text-align: center;">P2</div> <div style="border: 1px solid black; padding: 2px; display: inline-block; text-align: center;">3</div> ↓ SET	Sub Control Proportional band	Same as P1
<div style="border: 1px solid black; padding: 2px; display: inline-block; text-align: center;">I2</div> <div style="border: 1px solid black; padding: 2px; display: inline-block; text-align: center;">240</div> ↓ SET	Sub Control Integral Time	Same as I1
<div style="border: 1px solid black; padding: 2px; display: inline-block; text-align: center;">d2</div> <div style="border: 1px solid black; padding: 2px; display: inline-block; text-align: center;">60</div> ↓ SET	Sub Control Derivative Time	Same as D1
<div style="border: 1px solid black; padding: 2px; display: inline-block; text-align: center;">CYE2</div> <div style="border: 1px solid black; padding: 2px; display: inline-block; text-align: center;">10</div> ↓ SET	Sub Control Proportional Cycle	Same as CYT1
<div style="border: 1px solid black; padding: 2px; display: inline-block; text-align: center;">HYS2</div> <div style="border: 1px solid black; padding: 2px; display: inline-block; text-align: center;">1</div> ↓ SET	Sub Control Hysterisis	Same as HYS1
<div style="border: 1px solid black; padding: 2px; display: inline-block; text-align: center;">GAP1</div> <div style="border: 1px solid black; padding: 2px; display: inline-block; text-align: center;">0</div> ↓ SET	Main Control Gap (Output 1)	For output 2 use only, set the value turning "OFF" early to SP
<div style="border: 1px solid black; padding: 2px; display: inline-block; text-align: center;">GAP2</div> <div style="border: 1px solid black; padding: 2px; display: inline-block; text-align: center;">0</div> ↓ SET	Sub Control Gap (Output 2)	For output 2 use only, set the value turning "ON" early to SP
<div style="border: 1px solid black; padding: 2px; display: inline-block; text-align: center;">LCK</div> <div style="border: 1px solid black; padding: 2px; display: inline-block; text-align: center;">0000</div> ↓ SET	Function Lock	LCK=0100, To enter Level 1 & 2 and to change their parameters allowed. LCK=0110, To enter Level 1 & 2 and to change the parameters on Level 1 allowed. LCK=0001, To enter Level 1 only and to change SP allowed. LCK=0101, Nothing allowed except to change LCK.

Return to
'P1'

4.3 Level 3

When LCK=0000, press the SET key and SHIFT key for 5 seconds to enter level 3.

<div style="border: 1px solid black; padding: 2px; width: 60px; margin: 0 auto;">INP1</div> <div style="border: 1px solid black; padding: 2px; width: 60px; margin: 0 auto;">E2</div> <p style="text-align: center;">↓ SET</p>	<p>Main Control Input Selection</p>	<p>Select the input range. Refer to 5.1 Input selection on P.13~P.14</p>
<div style="border: 1px solid black; padding: 2px; width: 60px; margin: 0 auto;">ANL1</div> <div style="border: 1px solid black; padding: 2px; width: 60px; margin: 0 auto;">0</div> <p style="text-align: center;">↓ SET</p>	<p>Main Control Analog Zero set</p>	<p>Used as input code which are AN1 to AN5 Range: LSPL~USPL</p>
<div style="border: 1px solid black; padding: 2px; width: 60px; margin: 0 auto;">ANH1</div> <div style="border: 1px solid black; padding: 2px; width: 60px; margin: 0 auto;">5000</div> <p style="text-align: center;">↓ SET</p>	<p>Main Control Analog Span set</p>	<p>Same as ANL1</p>
<div style="border: 1px solid black; padding: 2px; width: 60px; margin: 0 auto;">DP</div> <div style="border: 1px solid black; padding: 2px; width: 60px; margin: 0 auto;">0000</div> <p style="text-align: center;">↓ SET</p>	<p>Decimal point</p>	<p>To set the position of decimal point</p>
<div style="border: 1px solid black; padding: 2px; width: 60px; margin: 0 auto;">LSPL</div> <div style="border: 1px solid black; padding: 2px; width: 60px; margin: 0 auto;">00</div> <p style="text-align: center;">↓ SET</p>	<p>Lower Set-point limit</p>	<p>To set the lowest point within INP1</p>
<div style="border: 1px solid black; padding: 2px; width: 60px; margin: 0 auto;">USPL</div> <div style="border: 1px solid black; padding: 2px; width: 60px; margin: 0 auto;">4000</div> <p style="text-align: center;">↓ SET</p>	<p>Upper Set-point limit</p>	<p>To set the highest point within INP1</p>
<div style="border: 1px solid black; padding: 2px; width: 60px; margin: 0 auto;">ANL2</div> <div style="border: 1px solid black; padding: 2px; width: 60px; margin: 0 auto;">0</div> <p style="text-align: center;">↓ SET</p>	<p>Sub Control Analog Zero set</p>	<p>Used as input code which are AN1 to AN5 Range: LSPL~USPL</p>
<div style="border: 1px solid black; padding: 2px; width: 60px; margin: 0 auto;">ANH2</div> <div style="border: 1px solid black; padding: 2px; width: 60px; margin: 0 auto;">5000</div> <p style="text-align: center;">↓ SET</p>	<p>Sub Control Analog Span set</p>	<p>Same as ANL2</p>
<div style="border: 1px solid black; padding: 2px; width: 60px; margin: 0 auto;">ALd1</div> <div style="border: 1px solid black; padding: 2px; width: 60px; margin: 0 auto;">01</div> <p style="text-align: center;">↓ SET</p>	<p>Alarm mode of AL1</p>	<p>Range: 00~19 Refer to '6.1 Alarm Function Selection' on P.15</p>
<div style="border: 1px solid black; padding: 2px; width: 60px; margin: 0 auto;">ALt1</div> <div style="border: 1px solid black; padding: 2px; width: 60px; margin: 0 auto;">0</div> <p style="text-align: center;">↓ SET</p>	<p>Time set of Alarm 1</p>	<p>Used in program function (Range: 0~99.59 min.) 0=switching, 99.59=continuous, others = on delay time</p>
<div style="border: 1px solid black; padding: 2px; width: 60px; margin: 0 auto;">ALd2</div> <div style="border: 1px solid black; padding: 2px; width: 60px; margin: 0 auto;">01</div> <p style="text-align: center;">↓ SET</p>	<p>Alarm mode of AL2</p>	<p>Range: 00~19</p>
<div style="border: 1px solid black; padding: 2px; width: 60px; margin: 0 auto;">ALt2</div> <div style="border: 1px solid black; padding: 2px; width: 60px; margin: 0 auto;">0</div> <p style="text-align: center;">↓ SET</p>	<p>Time set of Alarm 2</p>	<p>Same as ALT 1</p>
<div style="border: 1px solid black; padding: 2px; width: 60px; margin: 0 auto;">ALd3</div> <div style="border: 1px solid black; padding: 2px; width: 60px; margin: 0 auto;">01</div> <p style="text-align: center;">↓ SET</p>	<p>Alarm mode of AL3</p>	<p>Range: 00~19</p>
<div style="border: 1px solid black; padding: 2px; width: 60px; margin: 0 auto;">ALt3</div> <div style="border: 1px solid black; padding: 2px; width: 60px; margin: 0 auto;">0</div> <p style="text-align: center;">↓ SET</p>	<p>Time set of Alarm 3</p>	<p>Same as ALT 1</p>
<div style="border: 1px solid black; padding: 2px; width: 60px; margin: 0 auto;">HYSA</div> <div style="border: 1px solid black; padding: 2px; width: 60px; margin: 0 auto;">0</div> <p style="text-align: center;">↓ SET</p>	<p>Hysterisis of Alarm</p>	<p>Range: 0~1000</p>

↓			
CL01	Main Control	To calibrate the low value of output	
150	Calibration	Range: LSPL~USPL (Current output only)	
↓ SET			
CH01	Main Control	To calibrate the high value of output	
3500	Calibration high	Range: 0~9999 (Current output only)	
↓ SET			
CL02	Sub control	Same as CL01	
150	Calibration low		
↓ SET			
CH02	Sub Control	Same as CH01	
3500	Calibration high		
↓ SET			
CL03	Transmitter control	Same as CL01	
150	Calibration low		
↓ SET			
CH03	Transmitter control	Same as CH01	
3500	Calibration high		
↓ SET			
rUCY	Timer for	Full run time of proportional motor (without potentiometer)	
00	Motor valve control	Range: 5~200 sec	
↓ SET			
CA t	To use in program for	0=No wait	
0	waiting continued operation	Others = Wait time	
↓ SET			
SEtA	Relay Contact &	0= "a" contact, 1= "b" contact	
0000	Program RUN & End ALM	SET A.4=0 RUN alarm, SET A.4=1 END alarm	
↓ SET			
idn0	ID number	Communication ID number	
1	(please skip this step)		
↓ SET			
bAUD	Baud rate	UART band rate selection	
2400	(please skip this step)	Range: 110~9600 BIT/sec	
↓ SET			
SuOS	Compensate SP	Range: -1000~1000	
0			
↓ SET			
PvOS	Compensate PV	Range: LSPL~USPL	
0			
↓ SET			
Un t	Unit of PV & SP	Range: C, F, A (analog)	
C			
↓ SET			
SOft	Soft filter	Adjust the response time of PV (the bigger, the faster)	
1000	(please skip this step)	Range: 0.05~1.00	
↓ SET			

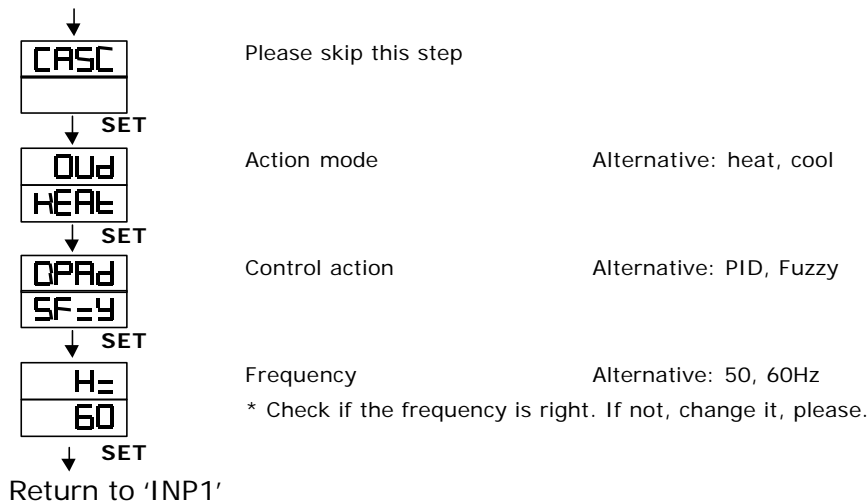

4.4 Level 4 (LOCK FUNCTION)

4.4.1 Functions of LCK

LCK=0100, To enter Level 1 & 2 and to change their parameters allowed.

LCK=0110, To enter Level 1 & 2 and to change the parameters on Level 1 allowed.

LCK=0001, To enter Level 1 only and to change SP allowed.

LCK=0000, To enter Level 3 allowed then press SET + SHIFT key (◀)

LCK=1111, To enter Level 4 allowed then press SET + SHIFT key (◀)

LCK=0101, Nothing allowed except to change LCK.

4.4.2 Let the display go to "LCK" in level 2, and set "1111" in LCK, then press SET key and SHIFT key (◀) for 5 seconds to enter "SET" status. There are SET0.1 to SET9.4 for use.

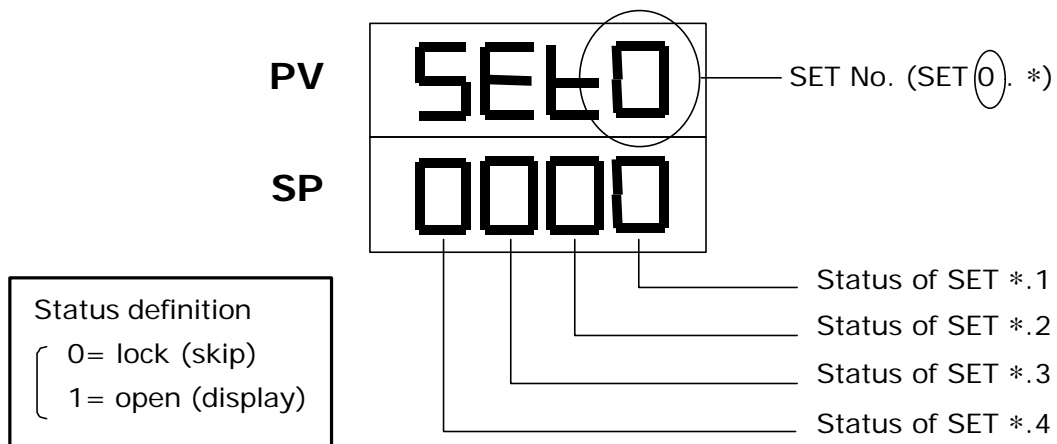

4.4.3 Functions of SETs

SET	Function	SET	Function
1.1	OUTL	5.1	CL02, CH02
1.2	AT	5.2	CL03, CH03
1.3	AL1	5.3	Rucy, WAIT, HYSM
1.4	AL2	5.4	IDNO, BAUD
2.1	AL3	6.1	SVOS
2.2	ANL1, ANH1, DP	6.2	PVOS
2.3	LSPL, USPL	6.3	UNIT
2.4	ANL2, ANH2	6.4	SOFT
3.1	ALD1	7.1	CASC
3.2	ALT1	7.2	ODD
3.3	ALD2	7.3	OPAD
3.4	ALT2	7.4	Hz
4.1	ALD3		
4.2	ALT3		
4.3	HYSA		
4.4	CL01, CH01		

SET	Function	Remarks
8.1	0= No Repeat	Program Use
	1= Program Repeat	
8.2	0= No Power Failure	
	1= With Power Failure	
8.3	0= Start from 0	
	1= Start from PV	
9.3	TRS SP	Auxiliary Output Use
9.4	TRS PV	
0.3	0= No Remote SP	
	1= Remote SP	

* Caution: Please don't operate SET8.4, otherwise the process of the controller will be in confusion.

4.5 Program Level

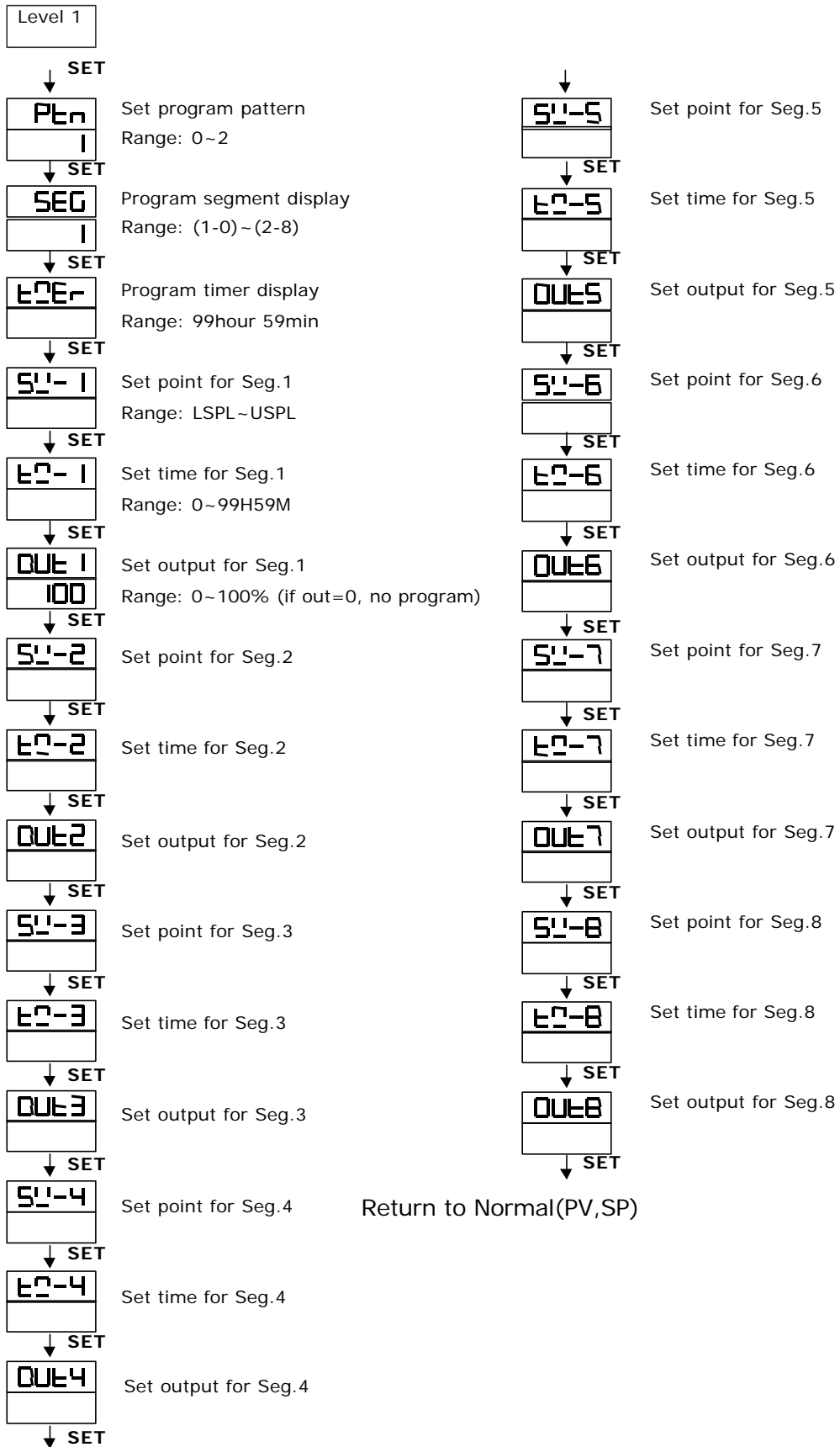

4.5.1 This program has 2 patterns, each pattern contains 8 segments. The segment can be arranged a period of RAMP status or SOAK status.

4.5.2 Terminologies

Pattern : A program consists of some segments

Step : A RAMP status + a SOAK status

RAMP status : The status with changing SP

SOAK status : The status with fixed SP

4.5.3 Operating

1) Key functions (No changing parameters)

△ (START) : To start program procedure, PRO in panel flicker

▽ (WAIT) : To suspend program procedure, PRO in panel will stop flicker but light

△+SET (JUMP) : To jump segment

▽+SET (RESET) : To reset program procedure, PRO in panel will be "off"

2) Alarm function

If ALD1 to be set 07 (*refer to the selection),

AL1 to be set 2 (AL1=2, it means alarm in segment 2 end),

ALT1 to be set 00.10 (alarm time 10 sec.).

*In this case, when program proceeds to segment 2 end, ALM1 relay will be on 10 sec.

3) End function

If ALD to be set 17 (* refer to the selection), this program will be end in segment 8 or 16.

* In this case, PV and END will flicker in display window, and the alarm relay acts.

This controller does not have END order if program procedure are less than 8 segments. In this case, please set next segment's out=0, then this program will be end in last set segment. Otherwise, it will proceed 8 or 16 segments.

4) Linking function

PTN=1, Proceed pattern1, which contains 8 segments

PTN=2, Proceed pattern2, which contains 8 segments

PTN=0, linking proceed pattern 1 and 2 ,totally 16 segments

(Set PTN1 and PTN2 first, then set PTN=0)

5) Other function (*refer to level 4)

SET8.1=1 Program repeat

SET8.2=0 No power failure

SET8.2=1 With power failure function

(If power suspended, the controller will keep the memory)

SET8.3=0 Program start from 0

SET8.3=1 Program start from PV

5. Input

5.1 Input selection (INP 1)

TYPE	CODE	RANGE	HEX
K	K1	0.0~200.0°C/0.0~392.0°F	01H
	K2	0.0~400.0°C/0.0~752.0°F	02H
	K3	0.0~600.0°C/0.0~1112.0°F	03H
	K4	0.0~800.0°C/0.0~1472.0°F	04H
	K5	0.0~1000.0°C/0.0~1832.0°F	05H
	K6	0.0~1200.0°C/0.0~2192.0°F	06H
J	J1	0.0~200.0°C/0.0~392.0°F	07H
	J2	0.0~400.0°C/0.0~752.0°F	08H
	J3	0.0~600.0°C/0.0~1112.0°F	09H
	J4	0.0~800.0°C/0.0~1472.0°F	0AH
	J5	0.0~1000.0°C/0.0~1832.0°F	0BH
	J6	0.0~1200.0°C/0.0~2192.0°F	0CH
R	R1	0.0~1600.0°C/0.0~2912.0°F	0DH
	R2	0.0~1769.0°C/0.0~3216.0°F	0EH
S	S1	0.0~1600.0°C/0.0~2912.0°F	0FH
	S2	0.0~1769.0°C/0.0~3216.0°F	10H
B	B1	0.0~1820.0°C/0.0~3308.0°F	11H
E	E1	0.0~800.0°C/0.0~1472.0°F	12H
	E2	0.0~1000.0°C/0.0~1832.0°F	13H
N	N1	0.0~1200.0°C/0.0~2192.0°F	14H
	N2	0.0~1300.0°C/0.0~2372.0°F	15H
T	T1	-199.9~400.0°C/-199.9~752.0°F	16H
	T2	-199.9~200.0°C/-199.9~392.0°F	17H
	T3	0.0~350.0°C/0.0~662.0°F	18H
W	W1	0.0~2000.0°C/0.0~3632.0°F	19H
	W2	0.0~2320.0°C/0.0~4192.0°F	1AH
PLII	PL1	0.0~1300.0°C/0.0~2372.0°F	1BH
	PL2	0.0~1390.0°C/0.0~2534.0°F	1CH
U	U1	-199.9~600.0°C/-199.9~999.9°F	1DH
	U2	-199.9~200.0°C/-199.9~392.0°F	1EH
	U3	0.0~400.0°C/0.0~752.0°F	1FH
L	L1	0.0~400.0°C/0.0~752.0°F	20H
	L2	0.0~800.0°C/0.0~1472.0°F	21H

* The initial set in factory mode is K2 without any certain requirement.

TYPE	CODE	RANGE	HEX
JIS Pt100	JP1	-199.9~600.0°C/-199.9~999.9°F	22H
	JP2	-199.9~400.0°C/-199.9~752.0°F	23H
	JP3	-199.9~200.0°C/-199.9~392.0°F	24H
	JP4	0.0~200.0°C/0.0~392.0°F	25H
	JP5	0.0~400.0°C/0.0~752.0°F	26H
	JP6	0.0~600.0°C/0.0~1112.0°F	27H
DIN Pt100	dP1	-199.9~600.0°C/-199.9~999.9°F	28H
	dP2	-199.9~400.0°C/-199.9~752.0°F	29H
	dP3	-199.9~200.0°C/-199.9~392.0°F	2AH
	dP4	0.0~200.0°C/0.0~392.0°F	2BH
	dP5	0.0~400.0°C/0.0~752.0°F	2CH
	dP6	0.0~600.0°C/0.0~1112.0°F	2DH
JIS Pt50	JP.1	-199.9~600.0°C/-199.9~999.9°F	2EH
	JP.2	-199.9~400.0°C/-199.9~752.0°F	2FH
	JP.3	-199.9~200.0°C/-199.9~392.0°F	30H
	JP.4	0.0~200.0°C/0.0~392.0°F	31H
	JP.5	0.0~400.0°C/0.0~752.0°F	32H
	JP.6	0.0~600.0°C/0.0~1112.0°F	33H
AN1	An1	-10~10mV/-1999~9999	34H
AN2	An2	0~10mV/-1999~9999	35H
AN3	An3	0~20mV/-1999~9999	36H
AN4	An4	0~50mV/-1999~9999	37H
AN5	An5	10~50mV/-1999~9999	38H

6. Alarm

6.1 Alarm function selection

CODE	DESCRIPTION	Hold-On
00/ 10	None	
01	Deviation high limit alarm	Yes
11	Deviation high limit alarm	No
02	Deviation low limit alarm	Yes
12	Deviation low limit alarm	No
03	Deviation high/low alarm	Yes
13	Deviation high/low alarm	No
04/ 14	Deviation high/low range alarm	No
05	Absolute value high limit alarm	Yes
15	Absolute value high limit alarm	No
06	Absolute value low limit alarm	No
16	Absolute value low limit alarm	Yes
07	Segment end alarm (use for program only)	-
17	Program run alarm (use for program only)	-
08	System error alarm-on	-
18	System error alarm-off	-
19	On delay timer alarm	-

* Note : "Hold-On" means the alarm does not work at the first time.

6.2 Alarm action description

6.1.1 CODE 00/10 : None

6.1.2 CODE 01 : Deviation high alarm inhibit



6.2.3 CODE 11 : Deviation high alarm no inhibit



6.2.4 CODE02 : Deviation low alarm inhibit



6.2.5 CODE12 : Deviation low alarm no inhibit



6.2.6 CODE03 : High/low alarm inhibit

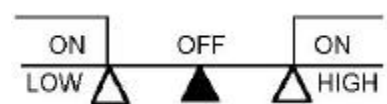

6.2.7 CODE13 : High/low alarm no inhibit

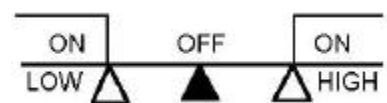

6.2.8 CODE04/14 : Band alarm

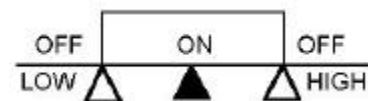

6.2.9 CODE05 : Absolute high alarm inhibit



6.2.16 CODE18 : System Error-OFF

<i>Normal</i>	<i>Error</i>
ON	OFF

AL

6.2.17 CODE19 : on delay timer
when PV=alarm SP, it keeps a certain period (set time)
before alarm action (Range: 00H00M~99H59M)

7. Modification of HEAT/ALARM → HEAT/COOL (on PC board)

7.1 DC1010

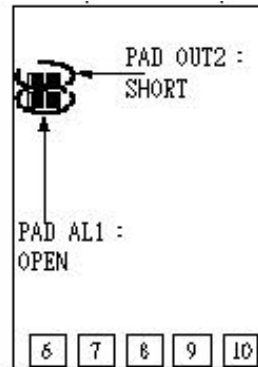
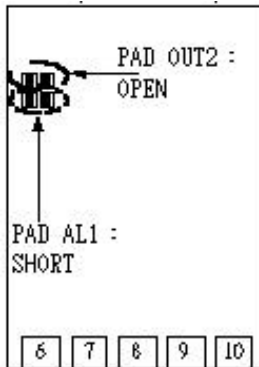

7.2 DC1030

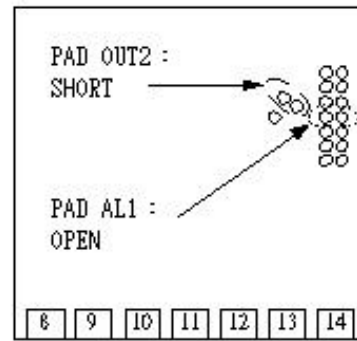
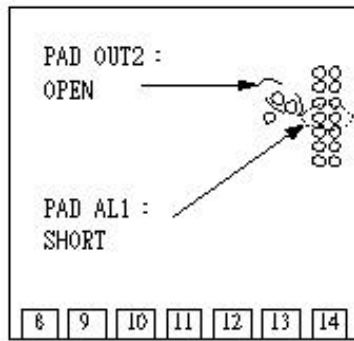

7.3 DC1020/1040

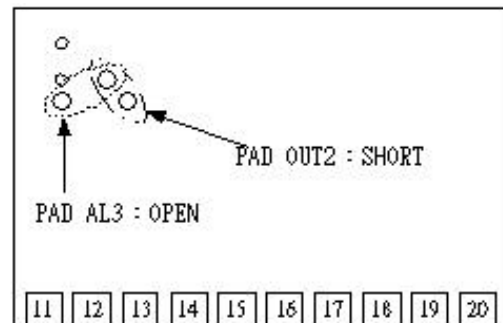
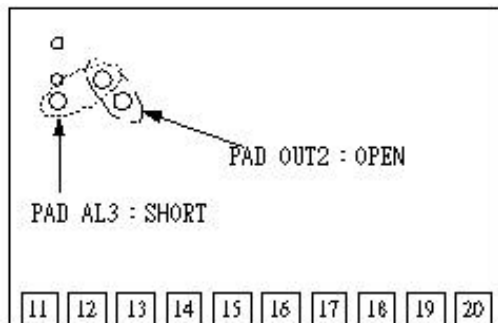

8. Special Function Description

8.1 Level set

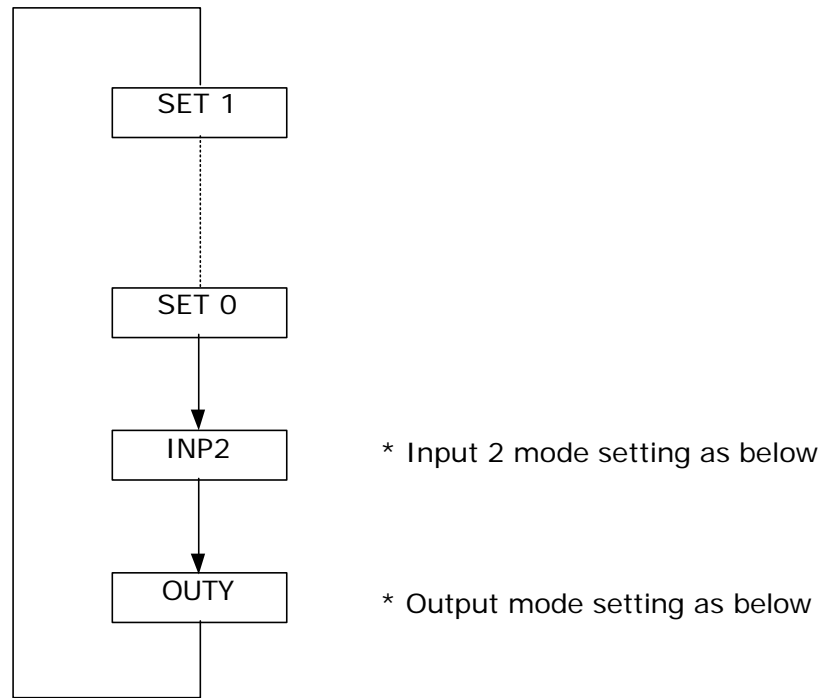

8.1.1 Second input mode

INP 2 = 0, Non

INP 2 = 1, 1~5V/4~20mA/2~10V

INP 2 = 2, 0~5V/0~20mA/0~10V

8.1.2 Output mode

OUTY = 0, Single output

OUTY = 1, Double output

OUTY = 2, Non

OUTY = 3, Motor Position Control

OUTY = 4, Single phase SCR (Single phase control)

OUTY = 5, Three phase SCR (Three phase control)

8.2 Ramp & Soak

8.2.1 RAMP

- i) Set "SET2.1= 1", "SET4.1= 1" at Set level
- ii) Set "ALD 3 = 9" at Input level
- iii) Then, "AL 3" menu will not be displayed

PV	RAMP	Range = 00.00~99.99 (°C/minute) If RAMP not used, set ALD 3 = 0
SP	0000	

8.2.2 SOAK

- i) ALD1/ALD2 = 19
- ii) Then, AL1/AL2 will be displayed

PV	AL 1	Range = 00.00~99.59 (hour/minute)
SP	0000	

Example)

SP = 100°C, RAMP = 10.00 °C/minute

Time(minute) = 10 minute → AL1 = 00.10

PV = 25°C

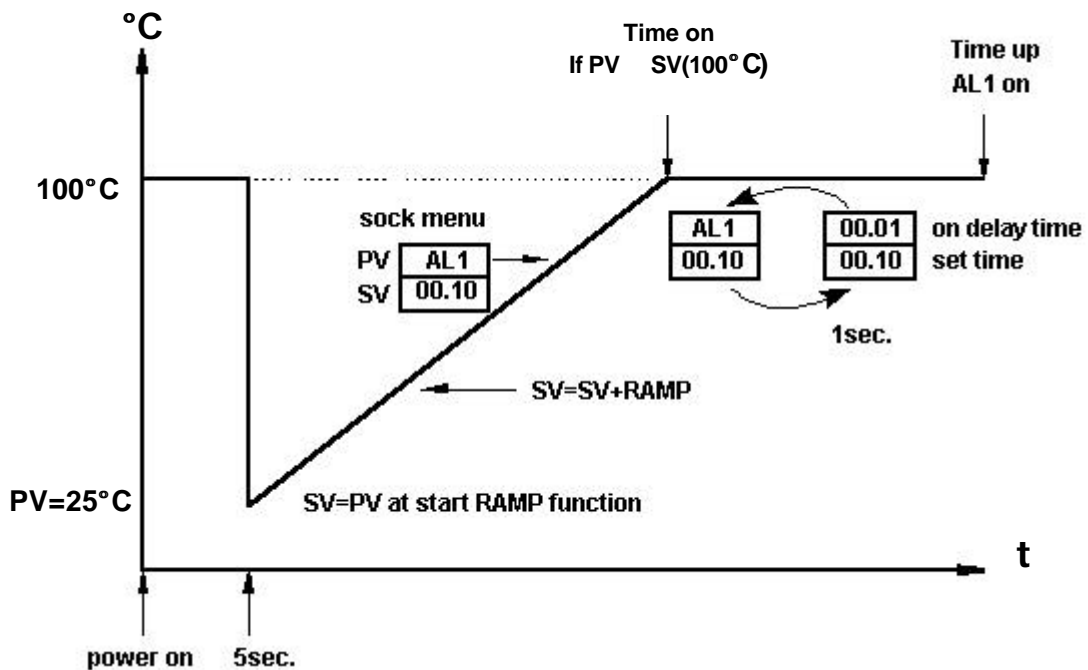

-
- 8.3 Remote SP
 - 8.3.1 Hardware must be mounted
 - 8.3.2 Set 'INP2' to 1 or 2 (ANL2, ANH2 used for Cal.)
 - 8.3.3 SET 0.3 = 1 means Remote SP from Input 2 channel
(*SET 0.3 = 0 means Local SP)
 - 8.4 Alarm Timer ALT1/ALT2/ALT3 description
 - 8.4.1 ALT 1 = 0 means Switching if AL 1 is ON
 - 8.4.2 ALT 1 = 99.59 means 'continuous alarm' if AL 1 is ON
 - 8.4.3 ALT 1 = 00.01~99.58 means AL 1 is on delay timer
 - 8.5 Function SET A

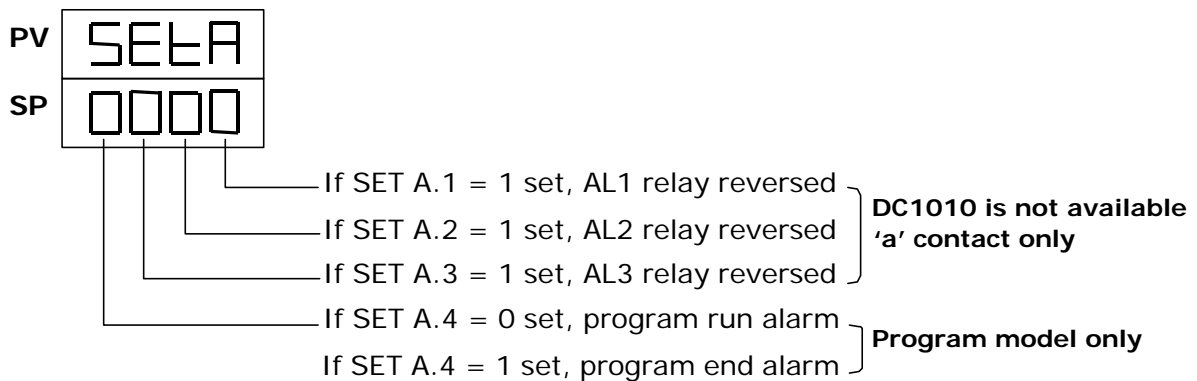

- 8.6 Function SET 8
 - 8.6.1 SET 8.1 = 0 Non
 - SET 8.1 = 1 Program Repeat
 - 8.6.2 SET 8.2 = 0 Non (program model only)
 - SET 8.2 = 1 Power failure access
 - 8.6.3 SET 8.3 = 0 Zero start (program model only)
 - SET 8.3 = 1 PV start
 - 8.6.4 SET 8.4 = 0 Non
 - SET 8.4 = 1 Display will be transferred to single display.
(Don't change this digit)
- * SET 8 = 0000 can make return to double display

-
- 8.7 Function SET 9
 - 8.7.1 SET 9.1 = 0 Non
 - SET 9.1 = 1 PV/SP switching
 - * This is for the single display set (refer to SET 8.4)
 - 8.7.2 SET 9.2 = 0 Non
 - SET 9.2 = 1 Non Program model : No display RAMP
 - Program model : Timer change from H.M to M.S
 - 8.7.3 SET 9.3 = 0 Non
 - SET 9.3 = 1 Transmission SP
 - 8.7.4 SET 9.4 = 0 Non
 - SET 9.4 = 1 Transmission PV

- 8.8 Function SET 0
- 8.8.1 SET 0.1 = 0 Non
- SET 0.1 = 1 Non (function not available for DC1010/1020/1030/1040)
- 8.8.2 SET 0.2 = 0 Non
- SET 0.2 = 1 Rate for AL3 (ALD 3 = 0)
- 8.8.3 SET 0.3 = 0 Non
- SET 0.3 = 1 Remote SP
- 8.8.4 SET 0.4 = 0 Motor valve close = "b" out (contact normally close)
- SET 0.4 = 1 Motor valve close = "a" out (contact normally open)

8.9 Input level wait

Wait = 0 means "no wait". When used as a programmer, i the

Wait ≠ 0 means "wait"

- 8.10 Cycle Time
- Range: 0~150 sec
- CYT1= 0 (i) mA
- (ii) Phase control(SCR)
- CYT1= 1 (i) SSR
- (ii) Phase zero control(SCR)
- CYT1= over 10 Relay output.

Application 1. Single Phase Control, Phase angle control

- Available models: DC1030/1040, DC1030P/1040P
- Data Change:
 - OUTY = 4
 - CYT = 0
 - CL01 = 0, CH01 = 5000 if used for resistance load
 - CL01 = 0, CH01 = 4000 if used for inductor load

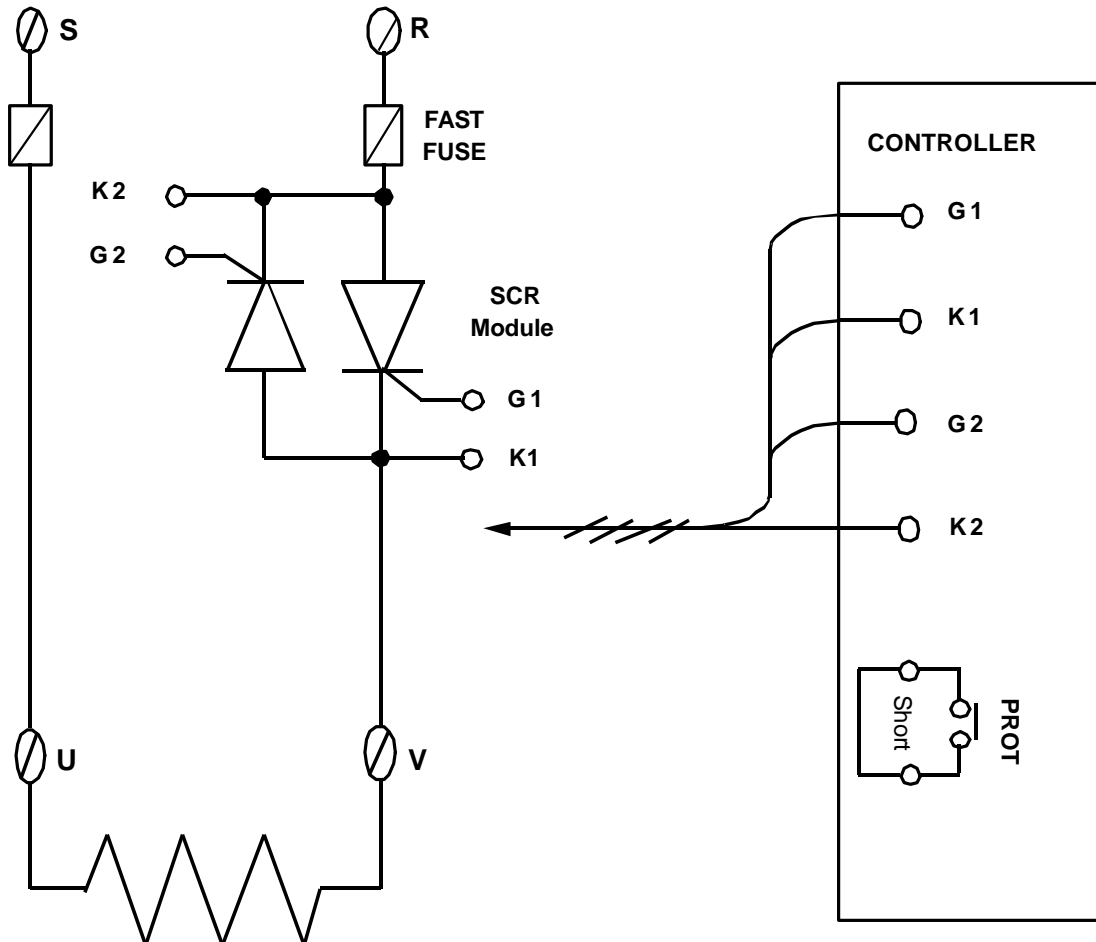

** Controller source phase must be same as load source phase

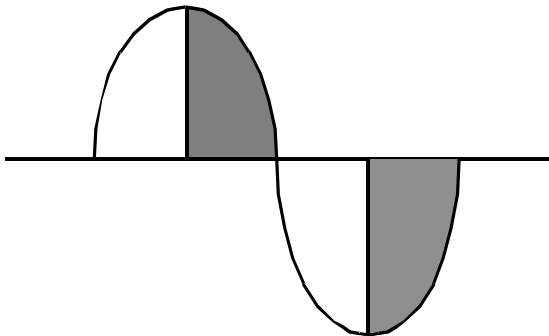

Application 2. Three Phase Control , Phase angle control

- . Available Models: DC1040/DC1040P
- . Data Change : OUTY = 5
CYT = 0
CL01 = 0, CH01 = 5000 only if used for resistance load

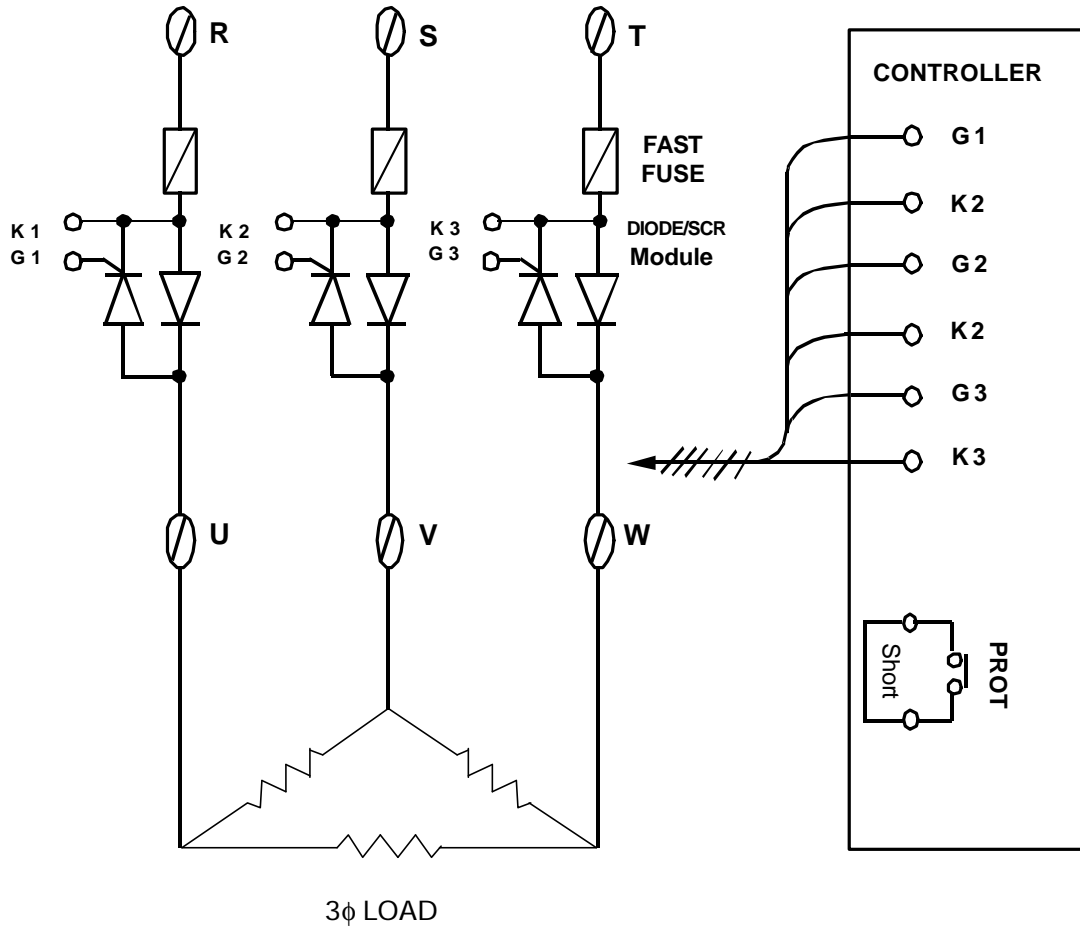

Application 3. Single Phase Zero crossover Control

- Available Models: DC1030/1040
DC1030P/1040P
- Data Change: OUTY = 0
CYT1 = 1

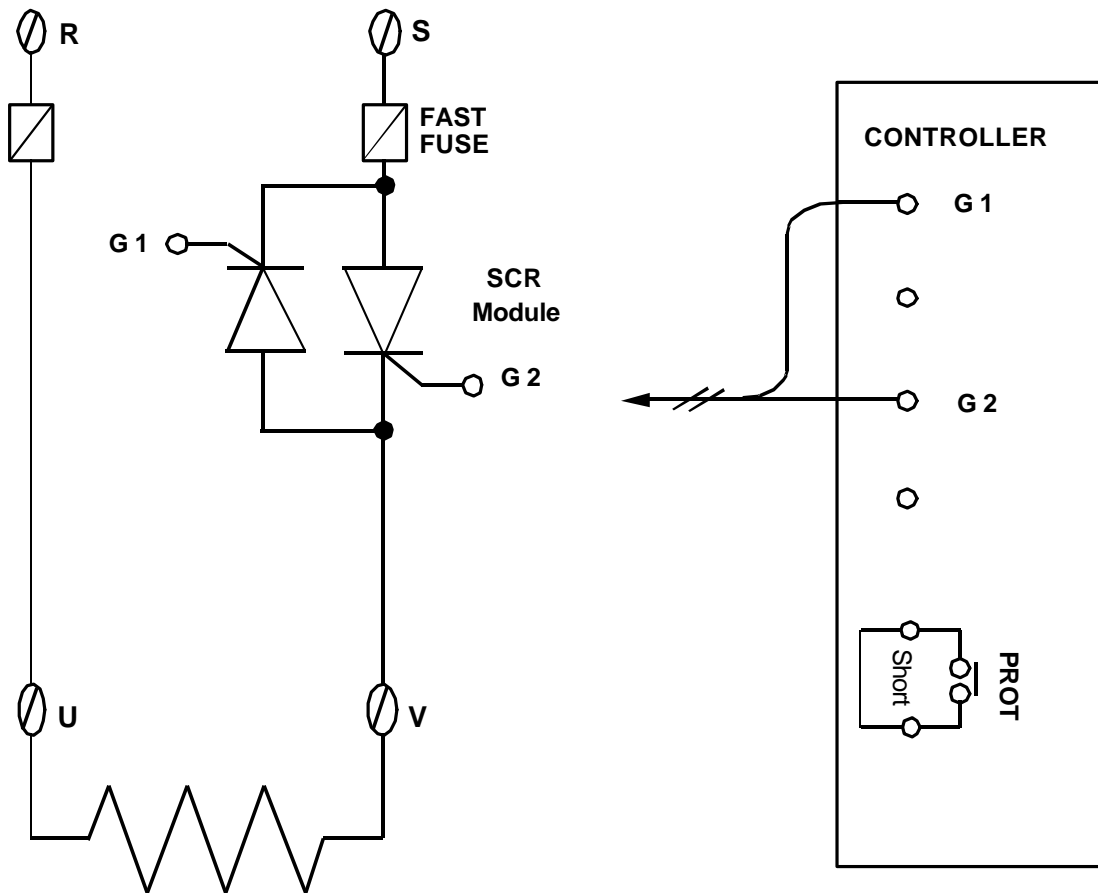

TIME CHART:

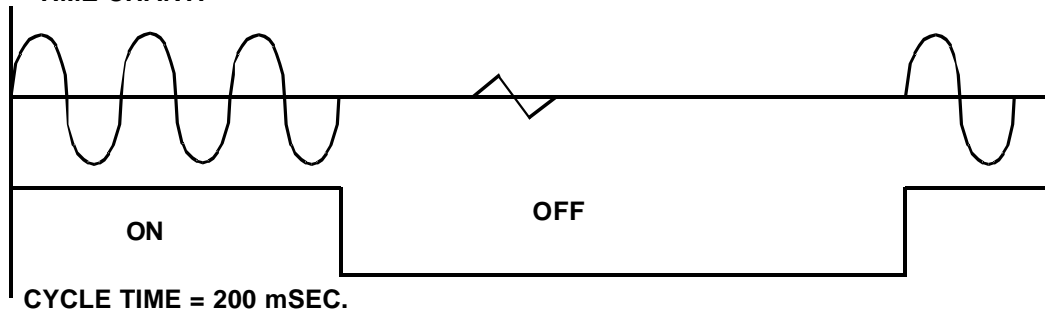

Application 4. Three Phase Zero crossover Control

- Available Models: DC1040/1040P
- Data Change: OUTY = 0
CYT1 = 1

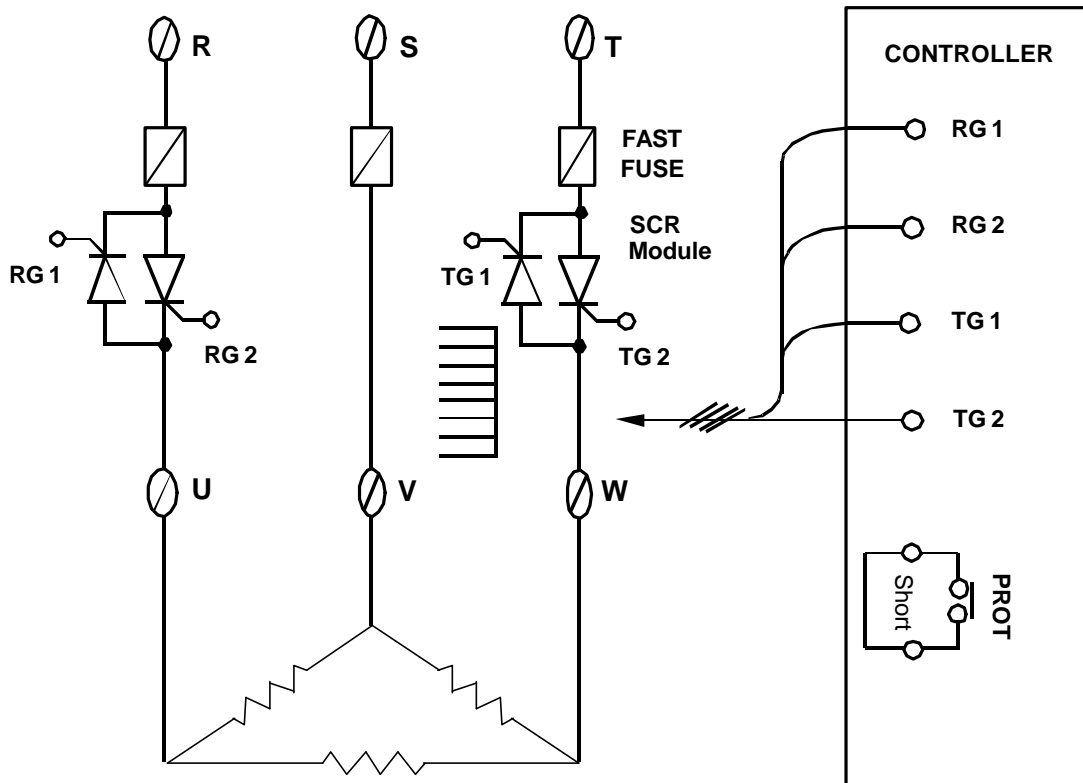

TIME CHART:

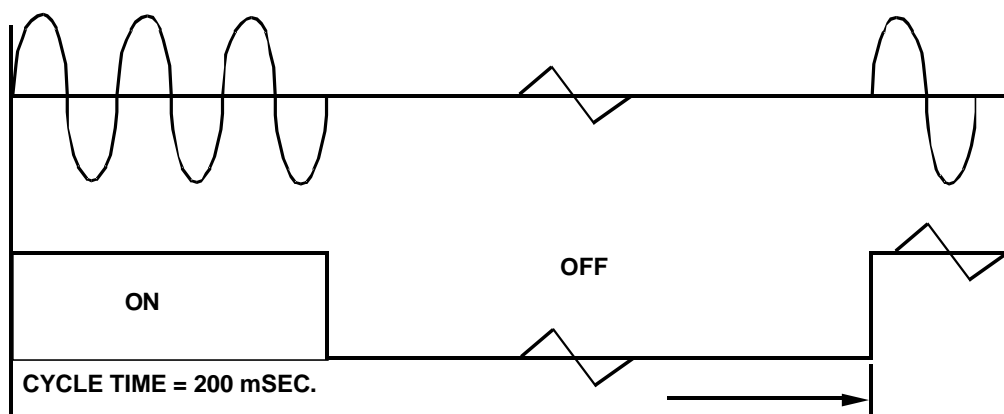

Application 5. Motor Valve Control

-. Available Models: DC1020/1030/1040
DC1020P/1030P/1040P

-. Data Change: OUTY = 3
CYT1 = 1~100 sec. (Normally, set 5 sec.)
RUCY = 5~200 sec.

- * 1. CYT1 is the cycle time of Open/Close
- 2. RUCY is the running time of motor valve 0~100%

MOTOR VALVE

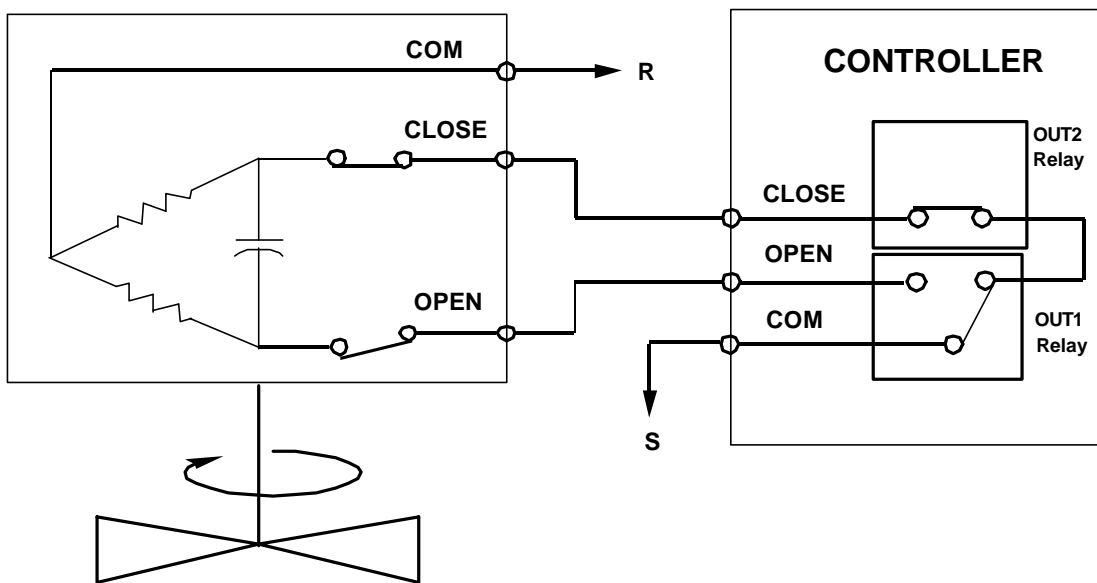

Application 6. Single Phase Control (for TRIAC module)

- Available Models: DC1030/1040
DC1030P/1040P
- Data Change: OUTY = 4
CLO1=0.CHO1=5000 if use for resistance load
CLO1=0.CHO1=4000 if use for inductor load

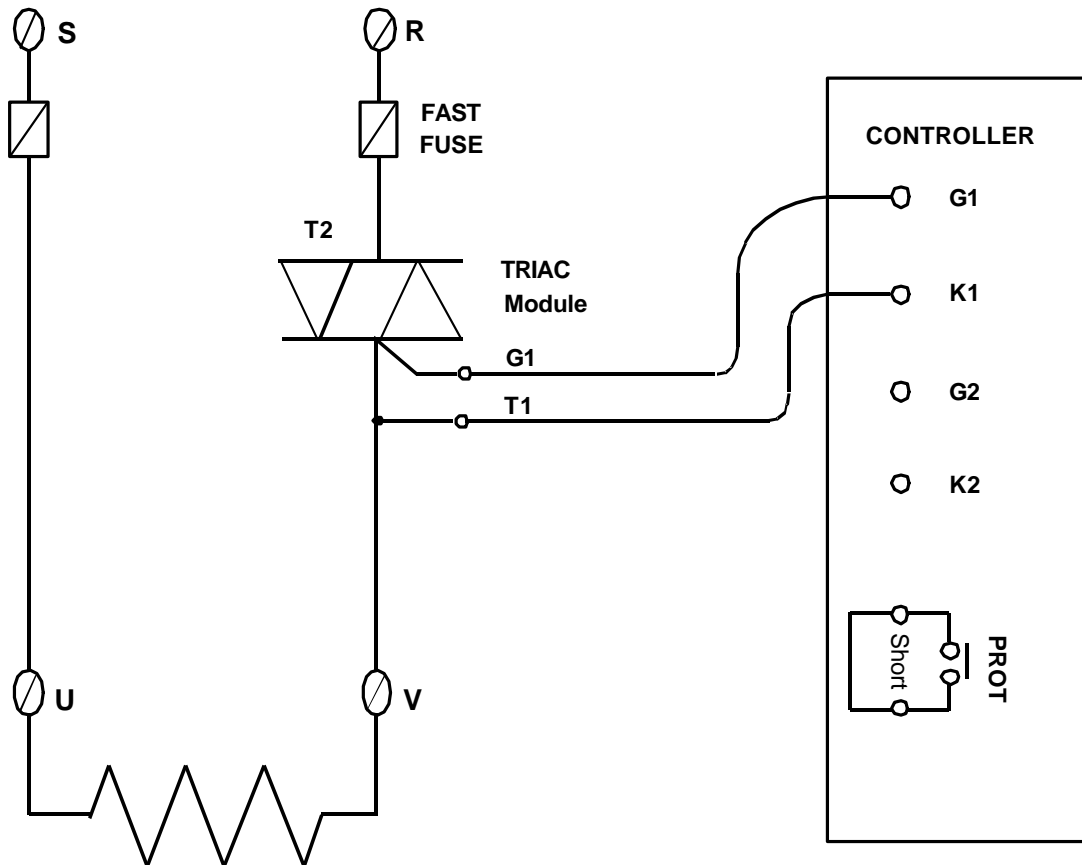

** Controller source phase must be same as load source phase

